

Tolerancing NEN 2731 (E) Tolerances acc. ISO 2768-mK-(E) / ISO 13920-AE  
 GPS - geometrical tolerancing acc. ISO 1101 Limits and fits acc. ISO 286  
 Surface texture acc. ISO 1302

Title:  
**CRANEBLOCK WLL 80 Mtons [88 UStons]**

80 Mtons [88 UStons]	Drawn: JS	Date: 14-05-12	Projection: 
	Checked:	Material: -	
-	Units: mm	Theoretical weight: 999.8 kg	Sheet: 1 / 2
1Bm DIN 15400	Format: A3	Treatment: -	
RB Standard, S.F. 4:1	Scale: 1:10	Drawing Number:	Revision: 00
Rev. Description:	Rev. Date:	Rev. by:	
SWL/WLL: -	<b>R121422-18</b>		

Ropeblock code:	FRB 450.22.3.80.E	SWL/WLL:
Customer ID:	-	Dynamic factor:
Wire rope:	ø 22 mm [7/8"]	Load group:
Hook size:	20V acc. DIN 15401	Design Acc.:
Target weight:	± 1000 kg [± 2200 lbs]	Personnel lift SWL:

THIS DOCUMENT AND ALL INFORMATION AND DATA DISCLOSED HEREIN OR HEREWITH ARE THE CONFIDENTIAL AND PROPRIETARY PROPERTY OF ROPEBLOCK AND ARE NOT TO BE USED, REPRODUCED OR DISCLOSED IN WHOLE OR IN PART BY OR TO ANYONE WITHOUT THE WRITTEN PERMISSION OF ROPEBLOCK.

POS.	QTY.	Drawing Number	Title	Material
1	1	01.20.V.E.253.C	Single hook 20V ACC. DIN 15401	34CrNiMo6
2	1	02.20.V.81222	HOOKNUT 20V - 81222	34CrNiMo6
3	1	03.140.91.240.43.B	TRAVERSE SRB 528.28.3.100	S355J2N
4	3	04G.450.5024.12	SHEAVE 450/120 R12 - MACHINING	GGG 50
5	1	05K.120.325	SHAFT ø120 FRB 528.26.3.80	34CrNiMo6
6	2	06.450.40.80	CHEEKPLATE FRB 450.26.3.80	S355J2N
7	2	R121422-17.07R	CHEEKWEIGHT FRB 450.22.3.80	S235J0
8	1	R121422-18.11	BECKET FRB 450.22.3.80	-
9	2	12A.20.355	BAR KB 528.26.3.100	AISI 304
10	2	14.25.242.368	HINGEBAR KB 528.24.3.63	S355J0
11	1	15.36.346	BECKETPIN KB 528.24.3.63	C35
12	2	18.450.242	REEVEGUIDE KB 450.19.3.50	S235J0
13	1	19.280.242	TOPPLATE KB 528.24.3.63	S235J0
14	1	21.170.25.8	RETAINER 170x25x8	S235J0
15	1	33.25.20.39	LOCKING GEAR ø25	S235J0
16	1	34.20.15.85	LOCKING PLATE HOOK 20	S355J2N
17	1	41.15.15.40	NOTCH 15x15x40mm	S235J0
18	2	50.110.4	CIRCLIP 110 A - DIN 471	Steel
19	1	50.120.4	CIRCLIP 120 A - DIN 471	Steel
20	2	50.36.2	CIRCLIP 36 A - DIN 471	Steel
21	2	51.EV.20.360	BOLT M20x360 - DIN 931	8.8
22	3	54.5024PP	Bearing SL04 5024-PP	Steel
23	1	54.81222	Bearing 81222	Steel
24	6	55.EV.20	Nyloc Nut M20 - DIN 985	8.8
25	2	56.EV.08.20	BOLT M8x20 - DIN 933	8.8
26	1	61.170A	Dirtseal 170A	NBR
27	4	63.6	Safety pin ø6	Galvanized Steel
28	1	64.20.E.B	Heavy duty safety latch kit with locking pin for S20/D25 - DIN 15401/2	Acc. Spec.
29	3	66.10.01	Lubrication nipple M10x1 - DIN 71412	Steel

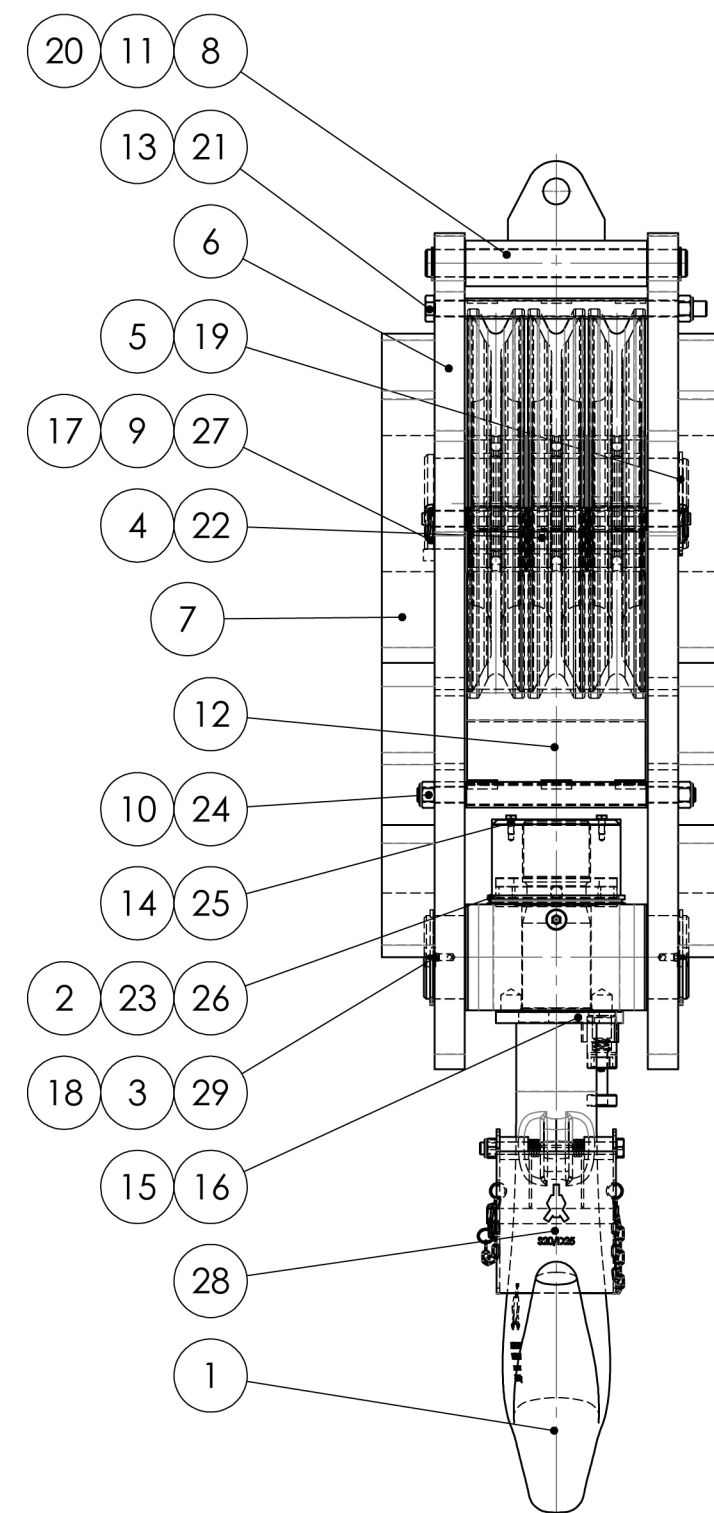

Tolerancing NEN 2731 (E) Tolerances acc. ISO 2768-mK-(E) / ISO 13920-AE		GPS - geometrical tolerancing acc. ISO 1101 Limits and fits acc. ISO 286		Surface texture acc. ISO 1302	
Title: <b>CRANEBLOCK WLL 80 Mtons [88 UStons]</b>					
Drawn: JS		Date: 14-05-12		Projection: 	
Checked:		Material: -		Sheet: 2 / 2	
Units: mm		Weight: 999.8 kg			
Format: A3		Treatment: -		Revision: <b>00</b>	
Scale: 1:10		Drawing Number: <b>R121422-18</b>			
Rev. Description:		Rev. Date:	Rev. by:		